

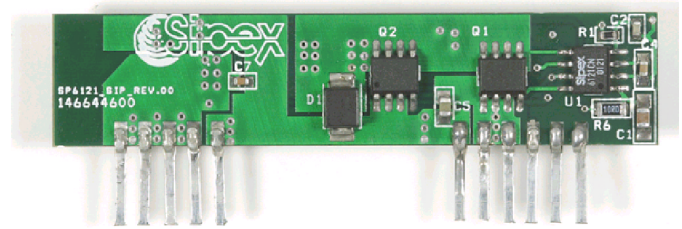

SP6121 Demo Board Manual

FEATURES

- DC/DC Synchronous Buck Converter for Distributed Power Systems.
- SIP design provides complete, ready to use solutions for :
 - $V_{in}=3.0 - 7.0V$
 - $V_{out}=1.25 - 5.0V$
 - $I_{out}=8.0A$ (*no air flow required*).
- High Efficiency: 86 to 95%
- Excellent Transient Response
- Small Size: 550X2500mils, vertical mounting
- Power Good output



DESCRIPTION

The **SP6121 DEMO Board** is designed to help the user evaluate the performance of the SP6121 for use in a distributed power system. The SP6121 operates over an input voltage range of 3.0V to 7.0V, and can deliver efficiencies as high as 95%. The SP6121 Demo Board is a complete Power Supply ready for use in applications where high stability, excellent transient response, high efficiency and power density are critical concerns.

The Demo Board, a completely assembled and tested PCB with surface mount components, has been designed as a SIP board that can be vertically mounted in an existing application.

BOARD SCHEMATIC and LAYOUT

The **SP6121 Demo Board** is configured as a highly efficient, synchronous DC/DC buck converter. It has been optimized to deliver excellent thermal and EMI performance.

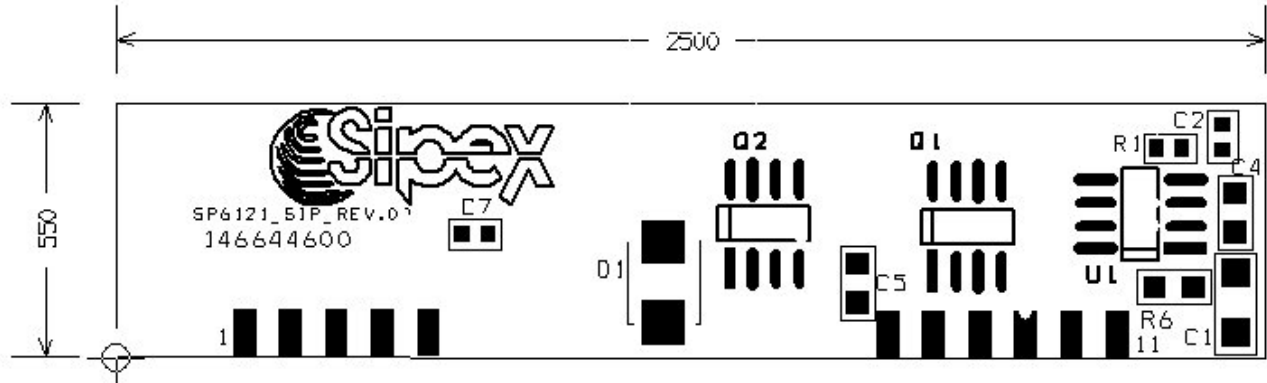

FIGURE 1. SP6121 Demo Board – layer 1, top view.

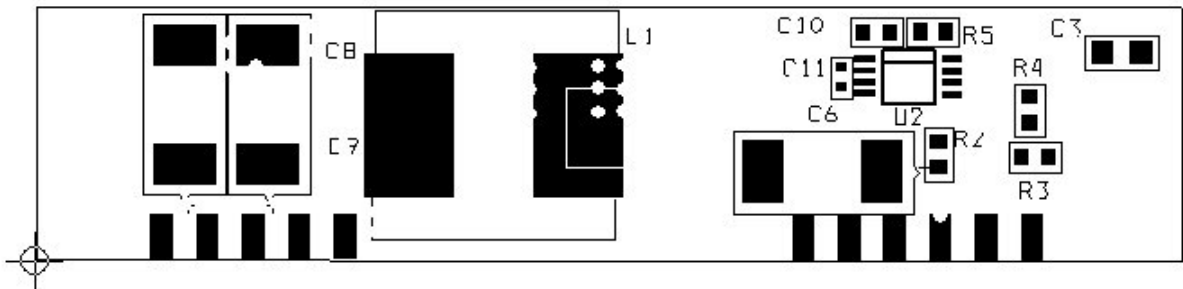

FIGURE 2. SP6121 Demo Board, layer 4, top view.

The SP6121 Demo Board has four, 2 oz copper layers that provide improved noise immunity and minimize power losses. Components are placed on the top and bottom sides of the PCB as shown on Figures 1 and 2. The row of pads (1 to 11) at the edge of the board is designed for solderable pins such as the NAS Interplex forked pins (17 x 42 mil cross section). Pin connections to the demo board circuit are indicated in Figure 3. (Pad 11 is a no connect.)

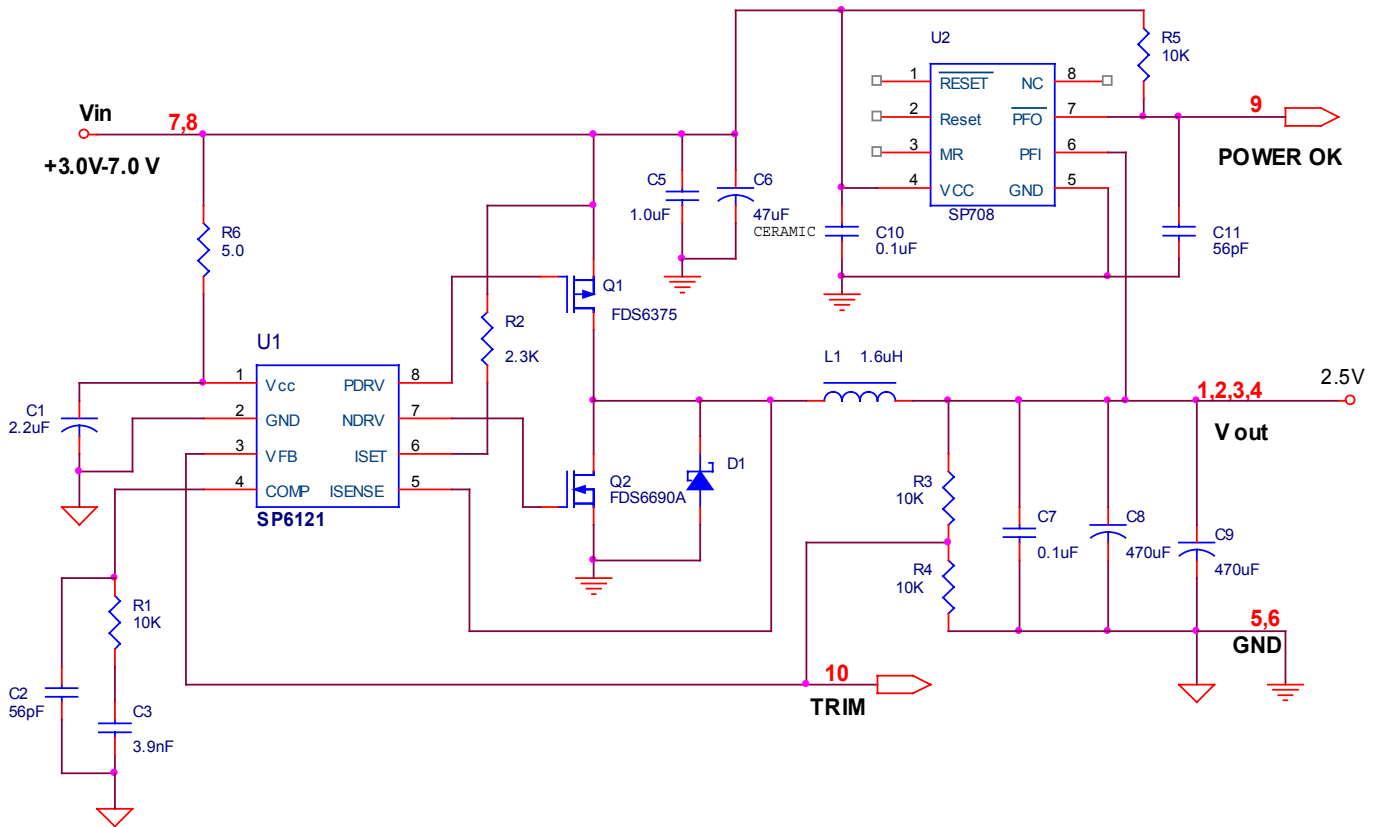

FIGURE 3. SP6121 Demo Board Schematic.

Demo Board Component Selection

The input capacitor, **C6**, can be either a ceramic or tantalum capacitor. Its choice depends on the user's system input voltage transient. If the highest possible efficiency is required, a ceramic **47uF** capacitor is recommended.

The demo board circuit includes a Schottky Diode, D1, across the low side switch. It prevents Q2's internal body diode from turning on and dissipating power during the nonoverlap time when both Q1 and Q2 are off. At a 500kHz switching frequency, these losses would decrease overall efficiency by 0.5 – 0.6%.

The output voltage is set by the resistor divider: R3/R4. The output voltage is calculated using the following:

$$V_{OUT} = \left(\frac{R_3}{R_4} + 1 \right) V_{REF} ,$$

where $V_{REF} = 1.25V$.

For the SP6121 demo board where $V_{OUT} = 2.5V$. Choosing R4 equal to 10K, then

$$R_3 = R_4 = 10K$$

The considerations, tradeoffs and calculations required to select the power MOSFETs (Q1, Q2), the inductor (L1), the input and output capacitors (C1, and C6, C8, and C9,

respectively), and the current set resistor (R_2), are discussed in detail in the SP6121 data sheet.

USING THE DEMO BOARD

To use the Demo Board, connect the input voltage, V_{IN} to pins **7** and **8** and a ground, GND, to pins **5** and **6**. Connect the load to pins **1**, **2**, **3**, and **4**. Pin **9** provides a logic level “power good” signal and Pin **10** is used for trimming the output voltage.

When measuring efficiency, care must be taken to keep leads between measuring devices, the power supply (V_{IN}) and the demo board as short as possible and the measurement probes should be connected to pins 4 (V_{OUT}) and 7 (V_{IN}).

The SP708 power management controller IC (U_2) on the demo board is used to generate a Power Good signal. On this demo board, when the voltage on the pin 6 (PFI) of U_2 is 1.25V or less, U_2 's pin 7 (PFO) goes LOW. Pin 6 can be connected directly, or through a resistor divider, to V_{OUT} or V_{IN} .

DEMO BOARD CHARACTERISTICS

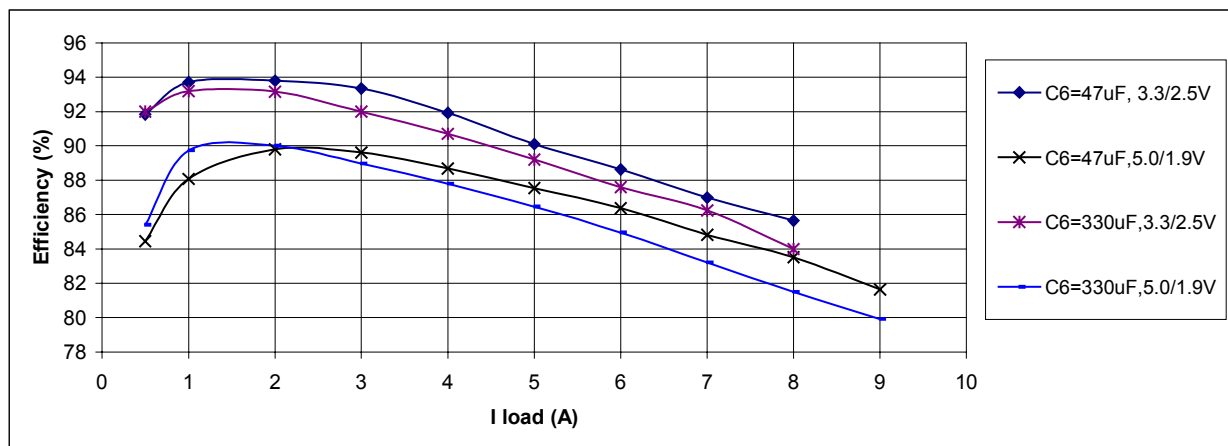

FIGURE 4. EFFICIENCY vs. I load. $V_{out}=2.5V$

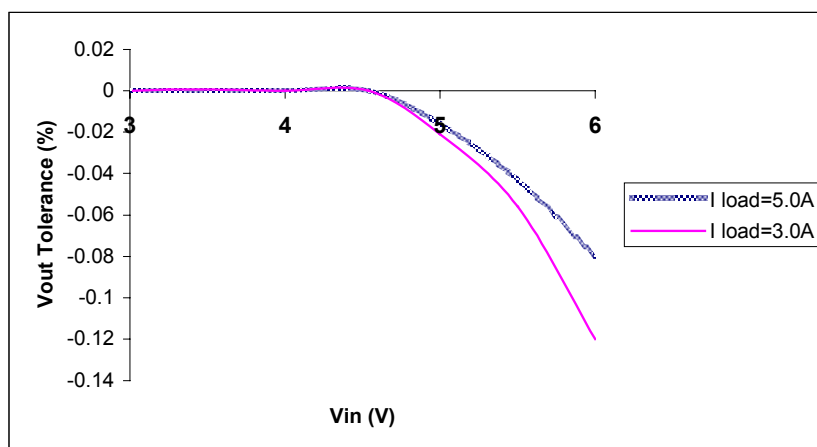

FIGURE 5. Line Regulation. $V_{out}=2.5V$

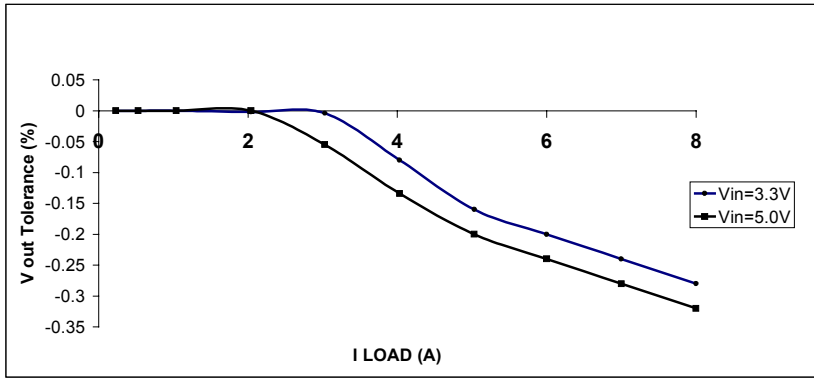

FIGURE 6. Load Regulation. $V_{out}=2.5V$

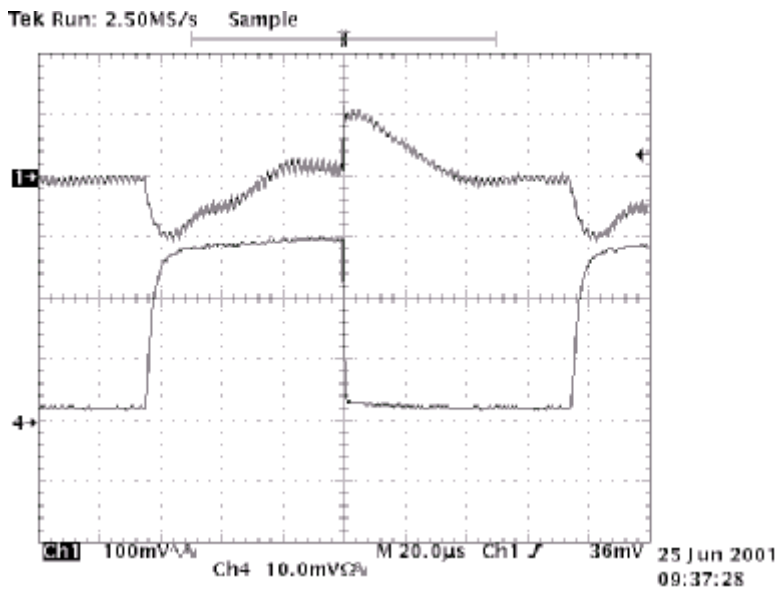

FIGURE 7. Load Step Response. I load step 0.4A to 6.0A. CH1-Vout; CH4-I load. $V_{in}=5.0V$, $V_{out}=2.5V$

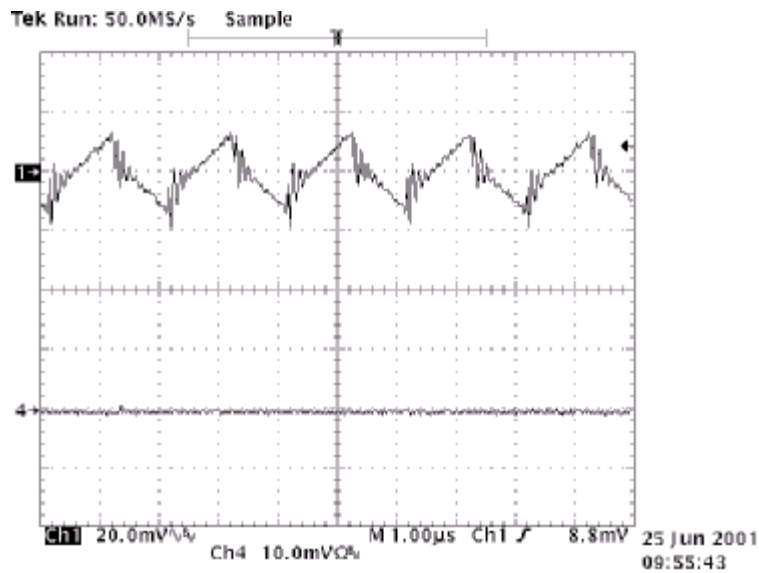

FIGURE 8. Output Ripple. $V_{in}=5.0V$, $V_{out}=2.5V$, $I_{load}=6.0A$

DEMO BOARD RECOMMENDED PARTS:

No.	Qty	Part	Manuf.	Manuf. P/N / PACKAGE
1	1	C1	Capacitor Ceramic 2.2uF/16V/X7R/10%	Any Approved Package 1206
2	2	C2,C11	Capacitor Ceramic 56pF/50V/X7R/10%	"_" 603
3	1	C3	Capacitor Ceramic 3.9nF/50V/X7R/10%	"_" 805
4	1	C5	Capacitor Ceramic 1uF/16V/X7R/10%	"_" 603
5	1	C6	Capacitor Tantalum 220uF/10V/10%	"_" 7343
		or	Capacitor Tantalum 330uF/10V/20%	"_" 1812
		or	Capacitor Ceramic 47uF/X7R/10V/10%	"_" 7343
6	2	C7,C10	Capacitor Ceramic 0.1uF/16V/X7R/10%	"_" 603
7	2	C8,C9	Capacitor Tantalum 470uF/10V/10%	"_" 7343
8	1	D1	Diode Schottky 30V/2.0A	"_" Package DO-214AA
9	1	L1	Inductor 1.6uH/15A/3.3 mOhm	PANASONIC ETQ-P6F1R6SFA
10	1	Q1	P-MOSFET 20V/8.0A/32mOhm	FAIRCHILD FDS6375/ SO-8
11	1	Q2	N_MOSFET 30V/13A/10mOhm	FAIRCHILD FDS6690A/ SO-8
12	2	R1,R5	Resistor 10K/63mW/5%	Any Approved Package 603
13	1	R2	Resistor 2.1K/63mW/5%	"_" 603
14	2	R4,R3	Resistor 10K/63mW/1%	"_" 603
15	1	R6	Resistor 10 Ohm/0.63mW/5%	"_" 603
16	1	U1	SYNCH. BUCK CONTROLLER	SIPEX SP6121/SO-8
17	1	U2	Low Power Microprocessor Supervisory Circuits	SIPEX SP708/ uSOIC-8
18	11	Pins	17X42 mils Cross Section	NAS Interplex